

# A Study on Data Transfer with Wireless Power Transfer Protocol

Ashvini Arya<sup>1</sup> and Diksha Lakra<sup>2</sup>

<sup>1</sup>Assistant Professor, Department of Information Technology, Madhav Institute of Technology and Science, Madhya Pradesh, India

<sup>2</sup>Assistant Professor, Department of Information Technology, Madhav Institute of Technology and Science, Madhya Pradesh, India

<sup>1</sup>Corresponding Author: 999ashvini9@gmail.com

Received: 10-04-2023

Revised: 29-04-2023

Accepted: 23-05-2023

## ABSTRACT

It systems allow power to be transferred from one electrical network to another electrical network without need for wires or exposed contacts. There has been rapid expansion of WPT in mobile phone chargers and electric bulb and charging electric vehicles and dynamic charging electric vehicles, also called road powered electric vehicles. It is expected that WPT industry will grow persistently in coming decades. , commonly wireless power transfers are conducted using an inductive coupling and followed by magnetic induction, we use magnetic induction using copper wire with a diameter. The wireless power transfer field would be in high demand for electric power to be supplied in the future.

**Keywords:** wireless, power transfer, data transfer, protocol

## I. INTRODUCTION

We live in a world where everyday new technologies are invented daily we want to use more smart technologies in our daily life. So the demand of the electricity increased as the technology improved. wireless power transfer system is based on transferring the electrical power without the use of wire as a physical link.

In older days people used wires connection to transferred the power from one transmitter to another receiver. Sometimes these wires links become hazardous. so to reduce these type of problems A new technology that is wireless power transfer system is invented. In an early 19th century, nicola tesla who was a famous inventor did experiment about wireless power transmission. In his experiment, he achieved the transfer of energy between two tesla coil and successfully used tesla coils to light a wireless bulb which lay the foundation for the development of wireless power transmission. Wireless power transfer system is based on two technologies radiative and non radiative in far field or radiative techniques also called power beaming power is transferred by beam of electromagnetic radiation like microwave or laser beam. Inductive coupling used generally for near field low range. Microwave used as far field high range technology. The need of wireless power transfer system it allows for charging of multiple device. This is achieved by changing the coil geometry as well as allocating large charging surface area such as table tops and charging benches. It give high charging speed. It allows for greater spatial freedom between the power source and the device prevent corrosion and sparking and also required low cost of wire.

## II. SYSTEM ARCHITECTURE

Wireless power transfer is a very efficient and economic way of transfer of power from one point to another point for short as well as long distances. There are so many problems occurring by transmission of power by wires which can be over come by Wireless Power Transfer. It reduces losses associated with wires. Wireless Power Transfer working is based upon Faraday law of Electromagnetic induction. Wireless Power Transfer consist of two sides that are transmitter and the receiver side. When main AC power of 230 V is supplied to the circuit, a high frequency step down transformer connected across it converts 230V to 13 V . The charging device receives Direct Current (DC) from a power source which is then converted to Alternating Current (AC) by the transmitter.

The rectifier converts AC to DC Voltage. The Oscillator connected across it produces continuous, repeated and alternating waveform. Due to the AC current, the transmitting coil within the transmitter becomes energized and produces magnetic field. When a receiving coil is placed near the transmitter, current is induced in receiving coil. Hence current will flow through the receiving coil by which we can use it for transmission of power. The charging cables are connected over the receiver side to connect the devices. Hence by connecting any devices to the charging cables we can charge our device.

The block diagram of Wireless Power transfer system is shown below in fig. 1.

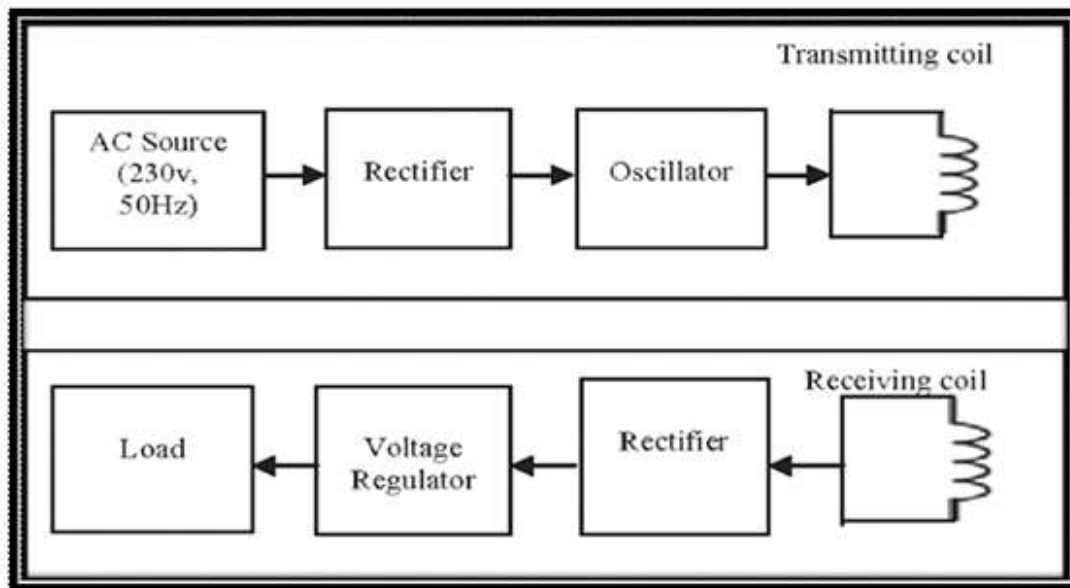

Figure 1: Block Diagram of Wireless Power Transfer System



Figure 2: Layout of Wireless Power Transfer System

### III. APPLICATION

1. Smart phone , Electric bulb, Digital camera and tablets
2. Public access charging terminal

### IV. ADVANTAGE

1. Wastage of power is less
2. Highly resonant strong coupling provides high efficiency over distance
3. Non-radiative energy transfer is safe for animals and people
4. Need for battery is eliminated
5. Maintenance cost is less

## V. LITERATURE REVIEW

This research paper simply explains the circuit that is used to glow a CFL and to charge a mobile phone by using two inductively coupled coils. Our project uses the principle of INDUCTIVE COUPLING for wireless power transfer, that is, the alternating magnetic field around a transmitter coil is induced in the receiver coil kept near to it through electromagnetic induction. The main components used here are a power supply, a transmitter and a receiver coil. As the power supply reaches transmitter coil; a magnetic field is produced, which is then induced in the receiver coil. Thus, the electrical power reaches to the load without making any physical connections and the CFL glows and the mobile starts to charge load of project.

## VI. FUTURE SCOPE

As the world's population continues to grow, the demand for electricity will increase and it will be difficult for us to transmit it around the world using wires and cables eventually, wireless power transfer will become a necessity the two ways to transfer power wirelessly are far-field and near-field. FAR-FIELD method uses laser or microwave transmission for long range energy transfers. NEAR-FIELD method uses inductive techniques or magnetic field to transfer energy across short distance.

"Really its about having power everywher you are, and not having to be limited by the amount of power you can carry with you in a batter or some other matter ,"explains joshua schwannecke ,an engineering manager at fulton innovation.

## VII. CONCLUSION

Wireless power transfer technology has the potential to change our planet to so many different levels. It not only reduces the need for cables or wires, it can also help in dealing with the problems like global warming, increasing pollution, unnecessary power losses occurring due to wired power transmission. Wireless Power Transfer can be seen in the nearfuture due to the new advancements made in the technologies. Whether it be handheld device charging or the electrical energy transference using wireless power transfer technology, all these can be done easily in the future by doing proper studies related to this technology.

## REFERENCES

1. [www.wikipedia.com](http://www.wikipedia.com).
2. [www.techlopedia.com](http://www.techlopedia.com).
3. Benson, Thomas W. *Wireless transmission of power now possible*.
4. Dombi J. (1982). Basic concepts for a theory of evaluation: The aggregative operator. *European Jr. Operation Research*, 10, 282-293.
5. M. Aurangzeb, P. A. Crossley, & P. Gale. (2000). *Fault location on a transmission line using high frequency travelling waves measured at a single line end in power engineering society*.
6. <https://www.researchgate.net>.